

VARISPEED-616G5 OPTION CARD
PG SPEED CONTROLLER CARD PG-A2
INSTRUCTIONS

Upon receipt of the product and prior to initial operation, read these instructions thoroughly, and retain for future reference.



NOTES FOR SAFE OPERATION

Read this instruction manual thoroughly before installation, operation, maintenance or inspection. In this manual, the NOTES FOR SAFE OPERATION is classified as “CAUTION”.

 **CAUTION**

Indicates a potentially hazardous situation which, if not avoided, may result in minor or moderate injury to personnel and damage to equipment.

It may also be used to alert against unsafe practices.

Even items described in  **CAUTION** may result in a vital accident in some situations. In either case, follow these important items.



: These are steps to be taken to insure proper operation and to avoid malfunctions, etc.

 **CAUTION**

- The option card uses a C MOS IC chips. It may break if touched by bare fingers because of static electricity. Be careful when handling.
- When removing the option card from the inverter for transportation or storage, put the card into the anti-static package it was in when delivered.
- Never change wiring or connect or disconnect connectors while the power is ON.

Failure to observe this caution may injure you.

PG speed control card, PG-A2 is mounted on the control board of the inverter, and performs speed feedback using the pulse generator (PG) on the motor to correct speed fluctuations caused by slipping. The card is used for v/f control with PG.

This option card is applicable to the following inverter series:
VS-616G5: Entire series

| Name | Code No. | Functions |
|-----------------------------|-------------|--|
| PG speed control card PG-A2 | 73600-A012X | <ul style="list-style-type: none"> · Phase A pulse (Single pulse) inputs. · PG frequency range : 50Hz to 30k32,767Hz · Pulse monitor output : +12V, 20mA (max.) |

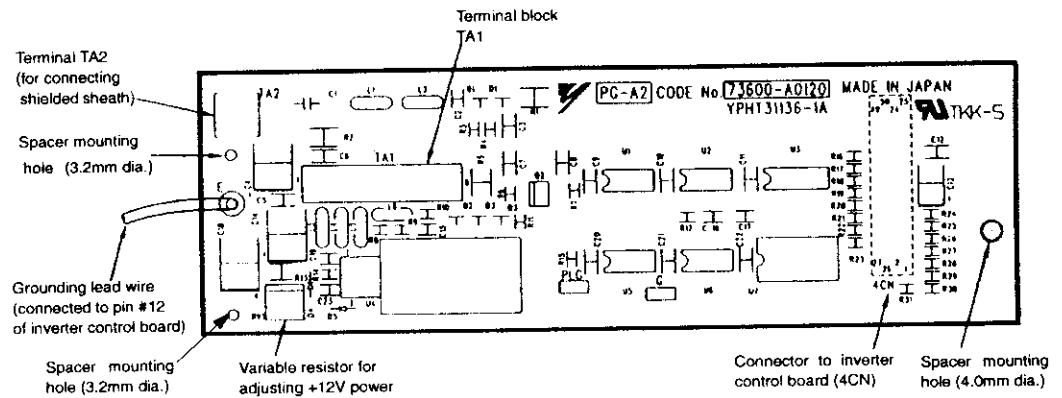

Fig. 1 PG speed control card PG-A2

Verify that the attachment below is in the package.

- Spacer : 1 pc. (Dimensions in mm)

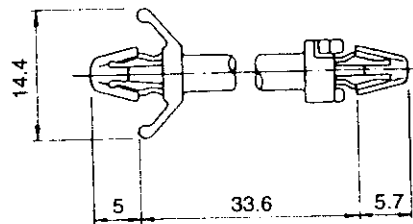

Fig. 2 Spacer (code no. SRNT41028-9)

NOTE

Before use,

- (1) Before using PG-A2, read this manual and the manual for the installation of the inverter.
- (2) Before connecting PG-A2 or external terminals, turn OFF main power of the inverter and verify the CHARGE indicator lamp of the inverter is OFF.
- (3) When ordering the PG-A2, specify the name and code number.

1 Inspection after Delivery

| |
|--|
|  CAUTION |
|--|

- | |
|--|
| <ul style="list-style-type: none">• Verify that ordered products have been delivered. Installation of a wrong device may lead to injury or damage. |
|--|

Though the products have undergone rigorous inspection before shipping, check the following for safety.

- Check the name written on the product to verify that ordered products have been delivered.
- Check for damage caused during transportation.

If there is anything uncertain on the structure, contact your YASKAWA representative.

2 Installing to Inverter (See Fig. 3)

2.1 Installation Procedure

- ① Turn OFF the main power and wait for the time specified on the cover of the inverter. Remove the cover and verify that the CHARGE indicator lamp is OFF.
- ② Insert the attached spacer (SRNT41028-9) into the spacer mounting hole in the mounting base of the inverter. (See Fig. 3.)

Inverters of 3.7kW or smaller capacities have two closely placed holes. Insert the spacer into the hole on the 7CN side. Inserting into the wrong hole will stack the spacer. Be careful to insert in the proper hole in the proper inserting direction.

- ③ Align the two holes of PG-A2 and projections as shown in the detailed side view, first at location (a) and then at (b), and precisely place the card on the option A connector. Insert the spacer mounted at ② above into the PG-A2 spacer mounting hole. (See part A of the side view.)

Verify that 4CN is precisely aligned to PG-A2. Gently push the card until it clicks.

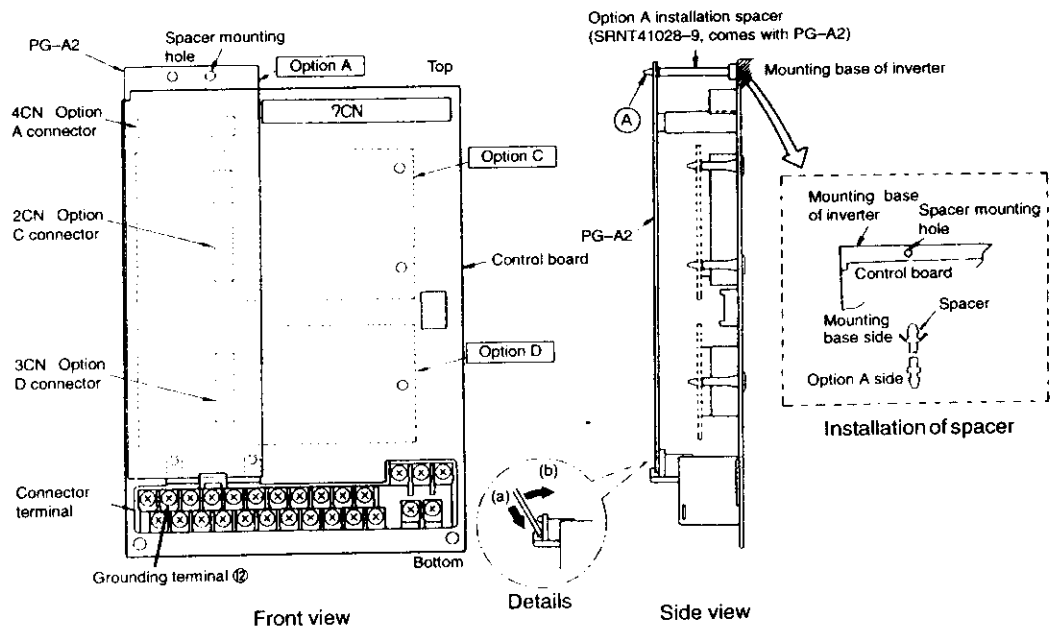

Fig. 3 Installation of PG speed control card PG-A2

3 Interconnection

Fig. 4 shows interconnection between the inverter, PG-A2, and peripheral equipment.

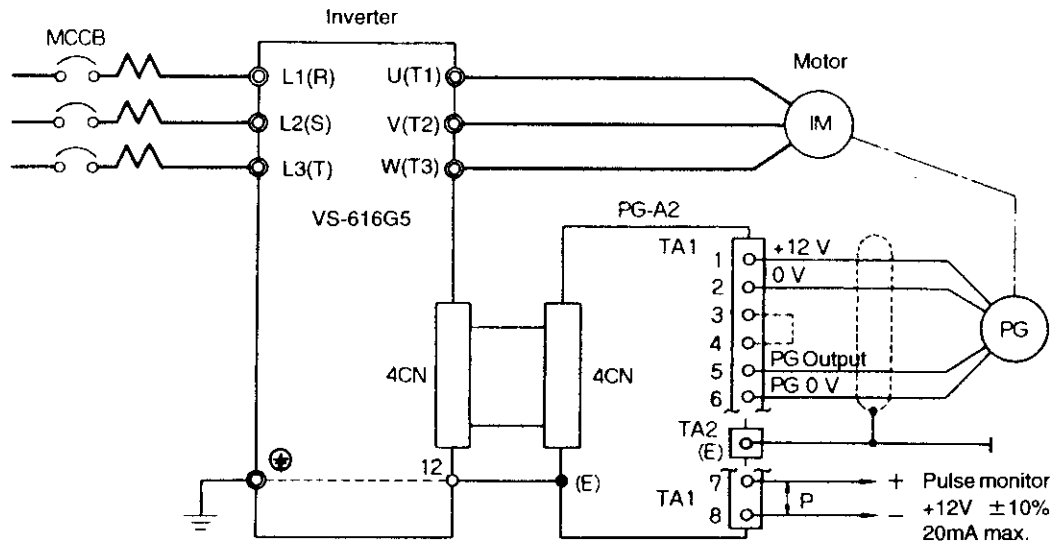

Fig. 4 Interconnection diagram



Notes on wiring

- Separate the control signal wires (from terminals TA1 and TA2) of the PG-A2 from the main circuit wires and other power cables.
- Use a shielded wire to connect to the PG. Connect the wire as shown in Fig. 5 to prevent interference by noise. The wire must be 50m or shorter.

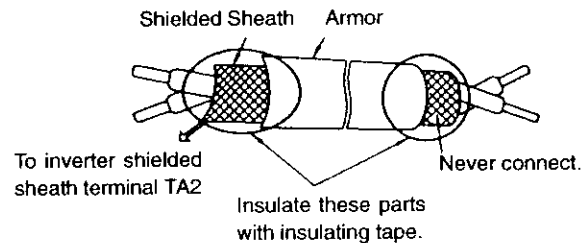

Fig. 5 Shielded wire termination

4 Wiring

See Table 1 for the functions of the external terminals.

Table 1 External terminals

| Terminal block symbol | Pin No. | | Functions | Remarks |
|-----------------------|-------------------------------------|--|--|---|
| TA1 | 1 | +12V | +12V power supply (+12V \pm 5%, maximum current 200mA)* | Power supplies for PG |
| | 2 | 0V | | |
| | 3 | Shorted between ③ and ④ when the inputting by open collector | | |
| | 4 | | | |
| | 5 | + | PG input signal | Signal input level H: +4V to +12V L: +1V or lower |
| | 6 | - | | |
| | 7 | + | Pulse monitor outputs (Duty depends on PG waveform) | Output voltage: 12V max. \pm 10% Output current: 20mA max. |
| | 8 | - | | |
| TA2 | Shielded sheath connection terminal | | | M3.5 screw terminal |

* Up to +14V \pm 5% can be supplied by adjusting variable resistor RV1. RV1 is set to 13.0V at the factory prior to shipment.

Make sure the followings when wiring.

- To prevent noise, use shielded wire and separate from heavy current circuits (200VAC or greater) or relay drive circuits. (Wire length to the PG connector must be 50m or shorter.)
- Connect both ends of the unused wire of the shielded wire to the 0V terminal.
- Connect the grounding lead wire (E) to pin ⑫ of the control board of the inverter.
- Applicable wire sizes for terminal block TA1 are shown below.
[Terminal: MKDS1 series manufactured by Phoenix Contact GmbH & Co.]

| | [mm ²] | AWG | I [A] | VAC [V] |
|-------------------|--------------------|-------|-------|---------|
| Thin twisted wire | 1 | 16 | 12 | 125 |
| Solid wire | 1.5 | 16 | 12 | 125 |
| UL | — | 22–16 | 10 | 300 |
| CSA | — | 28–16 | 10 | 300 |
| CSA | — | 28–16 | 10 | 150 |



Terminal block TA1 side
Connecting wire end



Notes on selecting cables

- Too thick a cable applies pressure to the option card and may lead to failure.
- Too thin a cable may lead to imperfect contact or a break in the wire.

5 Interface Circuit

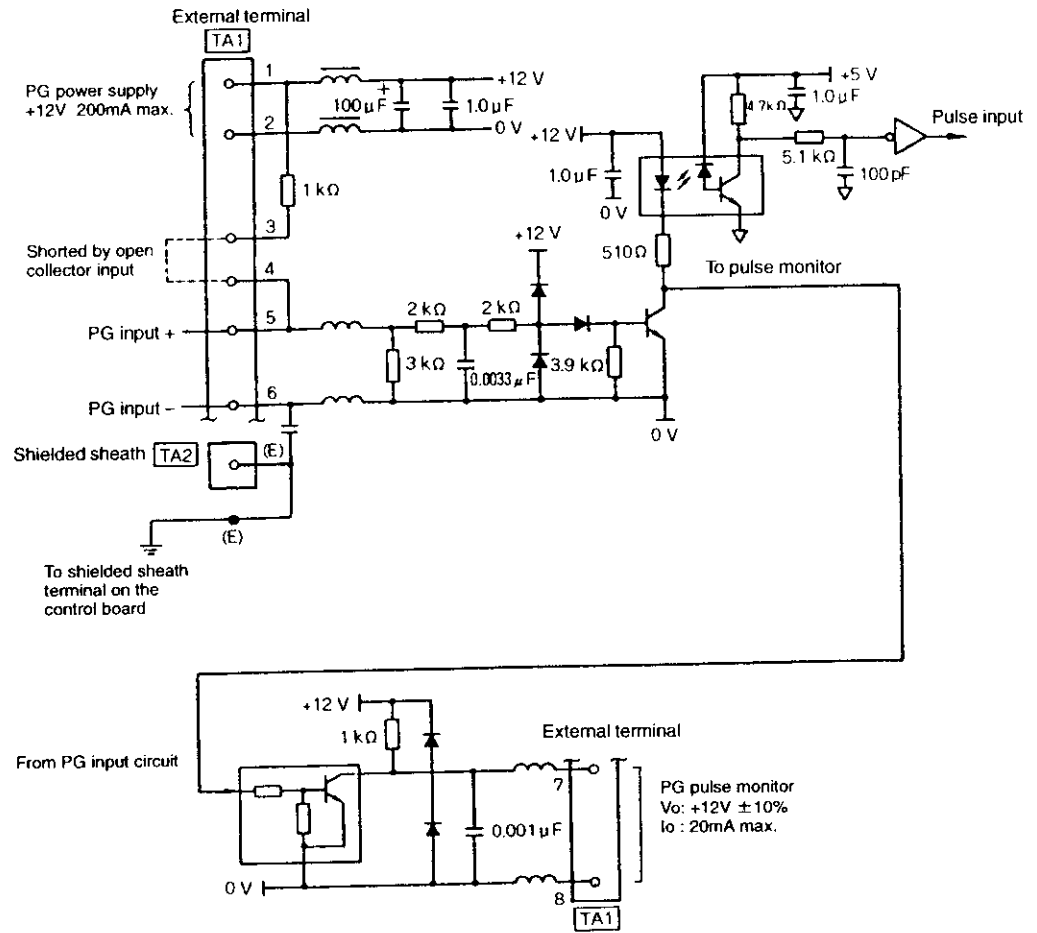

Fig. 6 PG input circuit and PG pulse monitor output circuit

6 Selecting PG

The maximum frequency of PG output pulse that can be detected is 30k32,767Hz. Therefore, select a PG that outputs about 20kHz at the motor rotation speed at maximum frequency output.

$$\frac{\text{Motor rotation speed (r/min) at max. frequency output}}{60} \times \text{PG constant (p/rev)} = 20,000\text{Hz}$$

Table 2 Examples of PG selection

| Motor rotation speed at maximum frequency output (r/min) | PG parameter (p/rev) | PG output frequency at maximum frequency output (Hz) |
|--|----------------------|--|
| 1800 | 600 | 18,000 |
| 1500 | 800 | 20,000 |
| 1200 | 1000 | 20,000 |
| 900 | 1200 | 18,000 |

- Notes:
- The motor rotation speeds at maximum frequency output are represented as synchronous rotation speeds.
 - PG power supply is +12V.
 - If the PG power capacity is 200mA or greater, provide a separate power supply. (If momentary power loss ride-through function is necessary, provide backup capacitor or take other necessary measures.)

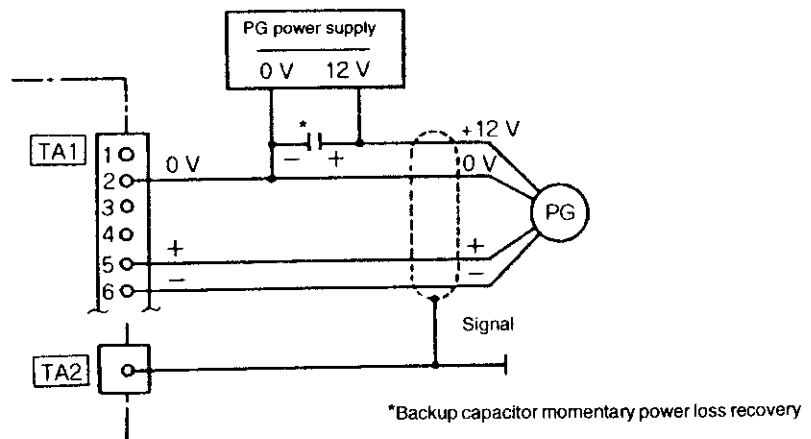

Table 3 Constants List

| Digital Operator Function Display | Digital Operator Display | Constant No. | Constant Name | Setting Range | Factory Setting | Change during Operation (○=Enable, ×=Disable) | Data Selection | Control Method (○=Setting enable, ×=Setting disable) | | | |
|-----------------------------------|--------------------------|--------------|--|----------------|-----------------|---|--|--|----------------------|------------------|-------------|
| | | | | | | | | V/f Control | V/f with PG Feedback | Open Loop Vector | Flux Vector |
| PG Option Setup | PG Pulse/Rev | F1-01 | PG constant | 0 to 60000 | 600 | × | | × | ○ | × | ○ |
| | PG Fdbk Loss Sel | F1-02 | Operation selection at PG open circuit | 0 to 3 | 1 | × | 0 : Ramp to Stop 1 : Coast to Stop 2 : Fast-Stop 3 : Alarm Only | × | ○ | × | ○ |
| | PG Overspeed Sel | F1-03 | Operation selection at overspeed | 0 to 3 | 1 | × | 0 : Ramp to Stop 1 : Coast to Stop 2 : Fast-Stop 3 : Alarm Only | × | ○ | × | ○ |
| | PG Deviation Sel | F1-04 | Operation selection at deviation | 0 to 3 | 1 | × | 0 : Ramp to Stop 1 : Coast to Stop 2 : Fast-Stop 3 : Alarm Only | × | ○ | × | ○ |
| | PG Ramp PI/I Sel | F1-07 | Integral value during accel/decel enable/disable | 0/1 | 0 | × | 0 : Disabled 1 : Enabled | × | ○ | × | × |
| | PG Overspd Level | F1-08 | PG overspeed detection level | 0 to 120% | 115% | × | | × | ○ | × | ○ |
| | PG Overspd Time | F1-09 | PG overspeed detection delay time | 0 to 2.0s | 1.0s | × | | × | ○ | × | ○ |
| | PG Deviate Level | F1-10 | Excessive speed deviation detection level | 0 to 50% | 10% | × | | × | ○ | × | ○ |
| | PG Deviate Time | F1-11 | Excessive speed deviation detection delay time | 0 to 2.0s | 1.0s | × | | × | ○ | × | ○ |
| | PG# Gear Teeth 1 | F1-12 | Number of PG gear teeth 1 | 0 to 1000 | 0 | × | | × | ○ | × | × |
| | PG# Gear Teeth 2 | F1-13 | Number of PG gear teeth 2 | 0 to 1000 | 0 | × | | × | ○ | × | × |
| ASR Tuning* | ASR P Gain 1 | C5-01 | ASR proportional gain 1 | 0 to 300.00 | 0.00 | ○ | | × | ○ | × | ○ |
| | ASR I Time 1 | C5-02 | ASR integral time 1 | 0 to 10.000sec | 0.00sec | ○ | | × | ○ | × | ○ |
| | ASR P Gain 2 | C5-03 | ASR proportional gain 2 | 0 to 300.00 | 0.00 | ○ | | × | ○ | × | ○ |
| | ASR I Time 2 | C5-04 | ASR integral time 2 | 0 to 10.000sec | 0.00sec | ○ | | × | ○ | × | ○ |
| | ASR Limit | C5-05 | ASR limit | 0.0 to 20.0% | 0.0% | × | | × | ○ | × | × |

*ASR = Automatic Speed Regulation

PG SPEED CONTROLLER CARD PG-A2 INSTRUCTIONS

TOKYO OFFICE Ohtemachi Bldg, 1-6-1 Ohtemachi, Chiyoda-ku, Tokyo, 100 Japan
Phone (03)3284-9111 Telex YASKAWA J33530 Fax (03)3284-9034

YASKAWA ELECTRIC AMERICA, INC.

Chicago-Corporate Headquarters 2942 MacArthur Blvd. Northbrook, IL 60062-2028, U.S.A.

Phone (847)291-2340 Fax (847)498-2430

Chicago-Technical Center 3160 MacArthur Blvd. Northbrook, IL 60062-1917, U.S.A.

Phone (847)291-0411 Fax (847)291-1018

MOTOMAN INC.

805 Liberty Lane West Carrollton, OH 45449, U.S.A.

Phone (513)847-6200 Fax (513)847-6277

YASKAWA ELÉTRICO DO BRASIL COMÉRCIO LTDA.

Avenida Brigadeiro Faria Lima 1664-5° CJ 504/511, São paulo, Brazil

Phone (011)825-7723 Fax (011)210-9781

YASKAWA ELECTRIC EUROPE GmbH

Am Kronberger Hang 2, 65824 Schwalbach, Germany

Phone (49)6196-569-300 Fax (49)6196-888-301

Motoman Robotics AB

Box 504 S38525 Torsås, Sweden

Phone 0486-10575 Fax 0486-41410

Motoman Robotec GmbH

Kammerfeldstraße 1, 85391 Allershausen, Germany

Phone 08166-900 Fax 08166-9039

YASKAWA ELECTRIC UK LTD.

3 Drum Mains Park Orchardton Woods Cumbernauld, Scotland, G68 9LD U.K.

Phone (1236)735000 Fax (1236)458182

YASKAWA ELECTRIC KOREA CORPORATION

Paik Nam Bldg. 901 188-3, 1-Ga Euljiro, Joong-Gu Seoul, Korea

Phone (02)776-7844 Fax (02)753-2639

YASKAWA ELECTRIC (SINGAPORE) PTE. LTD.

151 Lorong Chuan, #04-01, New Tech Park Singapore 556741, SINGAPORE

Phone (65)282-3003 Fax(65)289-3003

YATEC ENGINEERING CORPORATION

Shen Hsiang Tang Sung Chiang Building 10F 146 Sung Chiang Road, Taipei, Taiwan

Phone (02)563-0010 Fax (02)567-4677

SHANGHAI OFFICE Room No.8B Wan Zhong Building 1303 Yan An Road (West), Shanghai 200050, CHINA

Phone (86)6212-1015 Fax (86)6212-1326

TAIPEI OFFICE Shen Hsiang Tang Sung Chang Building 10F 146 Sung Chiang Road, Taipei, Taiwan

Phone (02)563-0010 Fax (02)567-4677



YASKAWA

YASKAWA ELECTRIC CORPORATION

MANUAL NO. TOE-C736-40.1

© Printed in Japan April 1996 95-12 0.5 ◆